

# PUNZONES FERRY PARA PLEGADORA

## TIPO PROMECAM

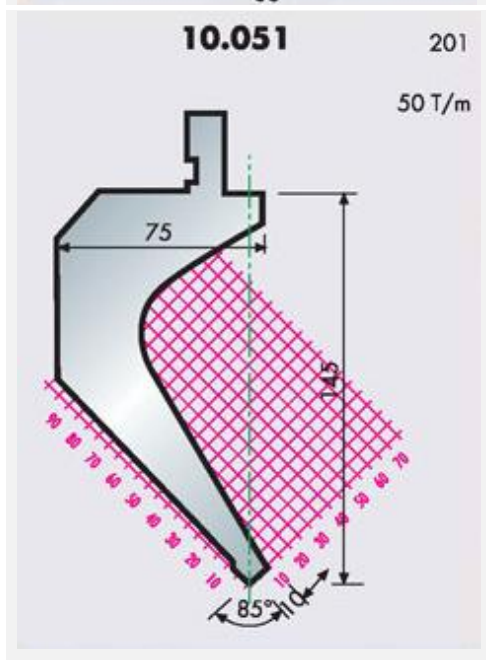
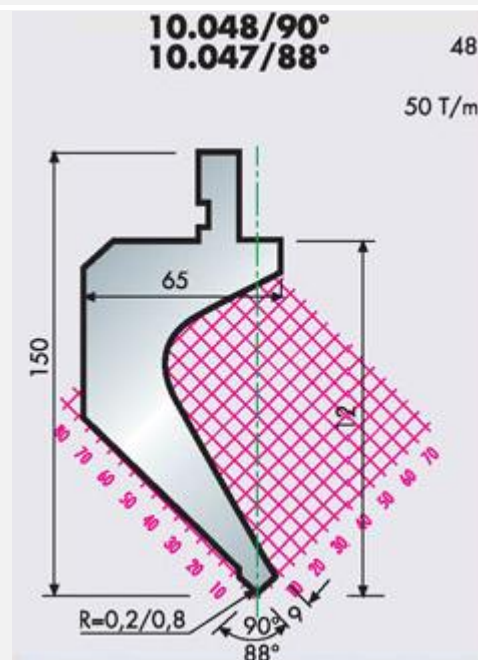
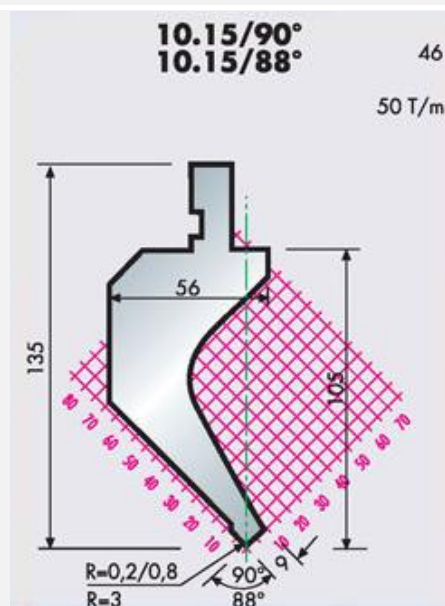
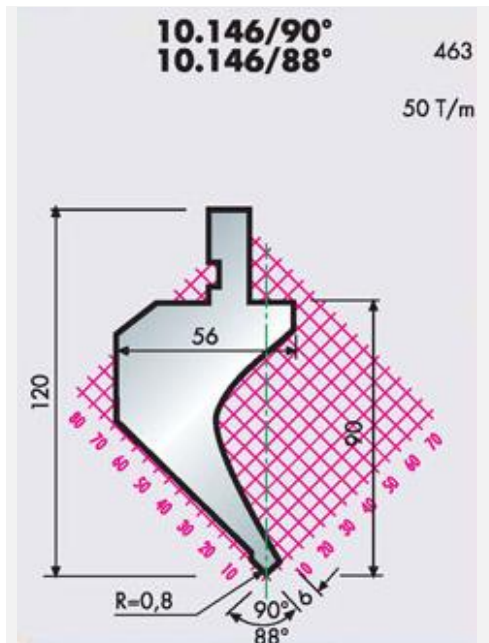
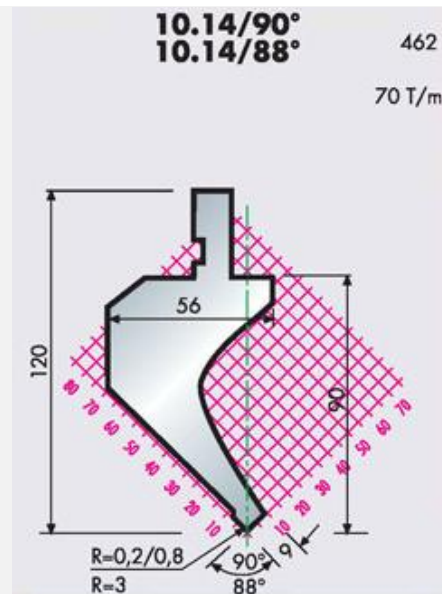
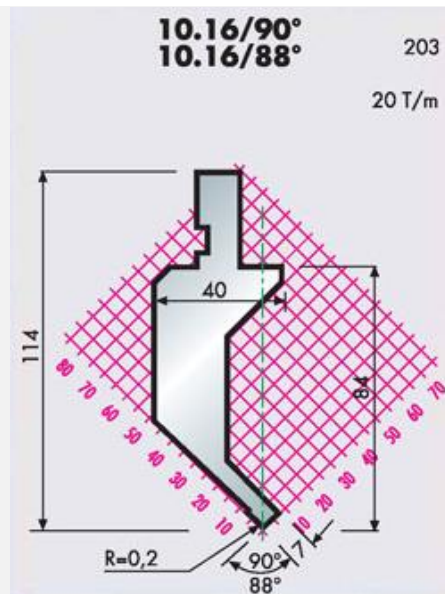
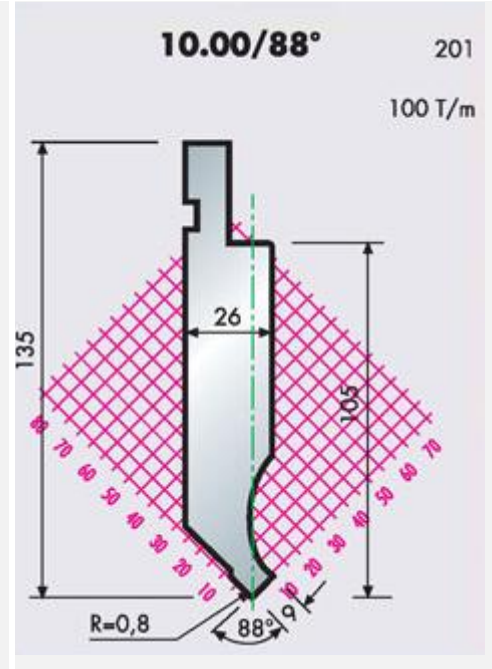
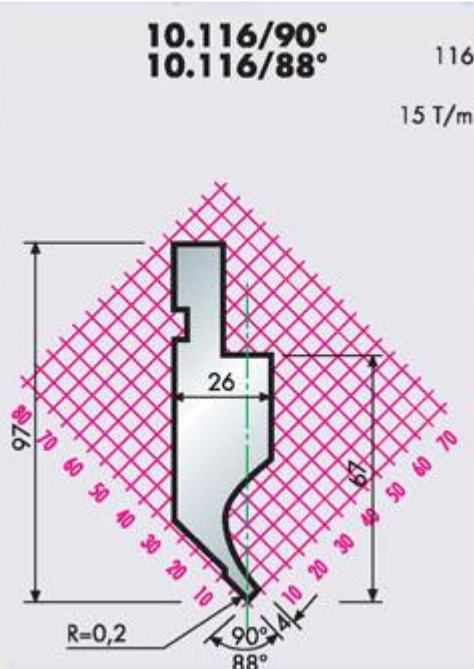
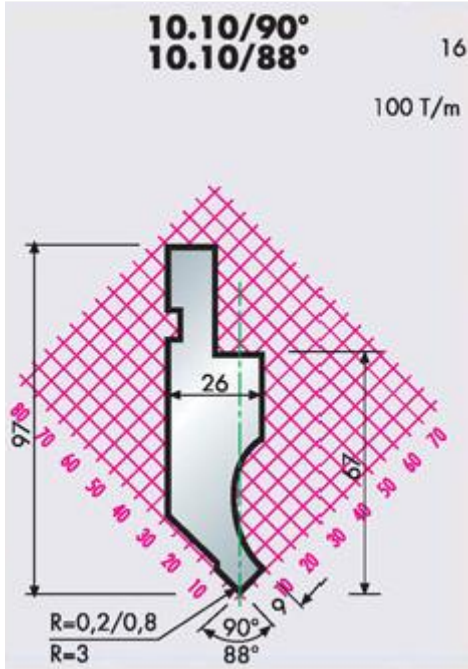

# PUNZONES FERRY PARA PLEGADORA

## TIPO PROMECAM

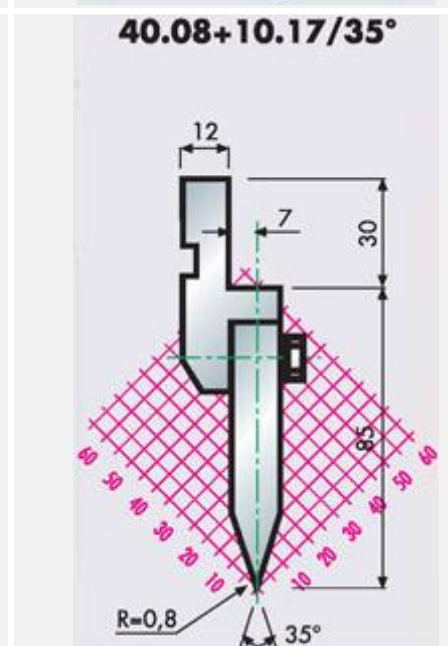
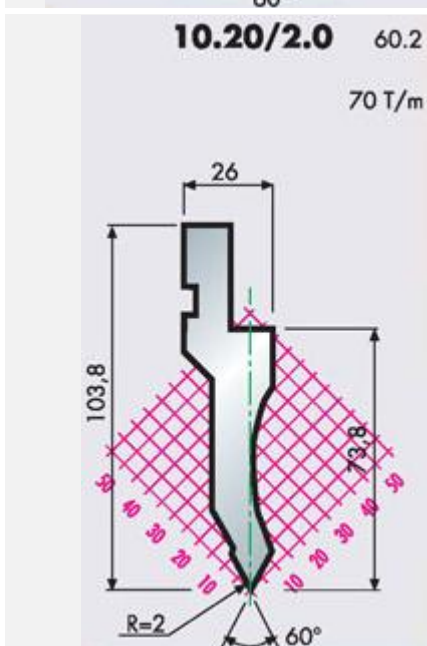
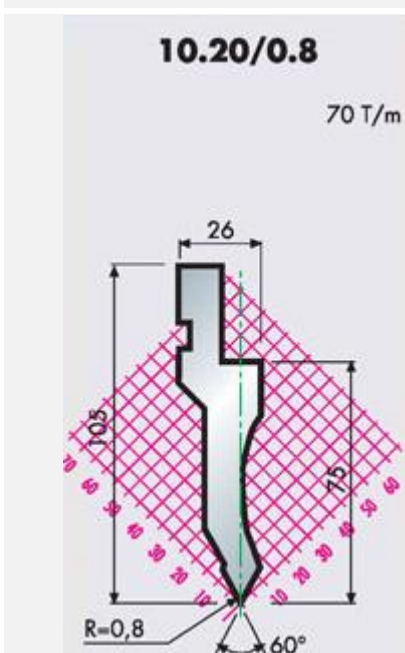
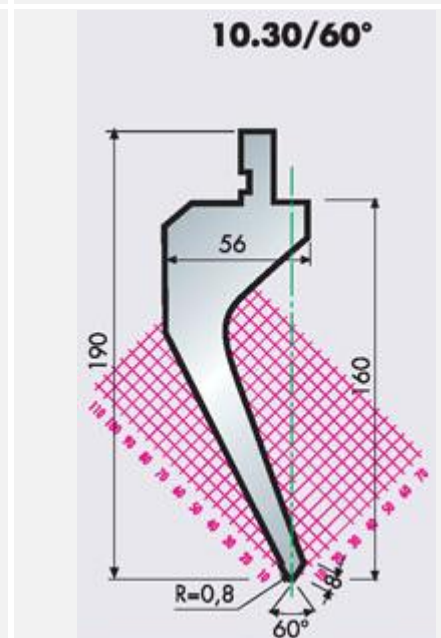
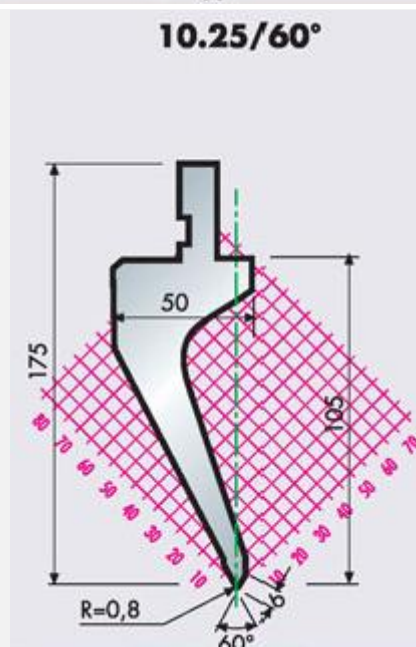
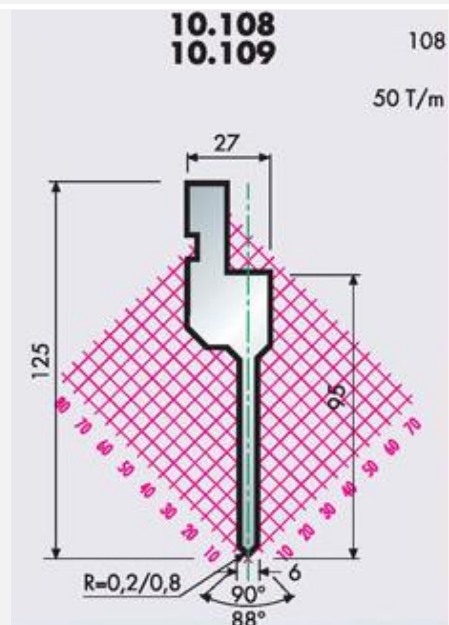
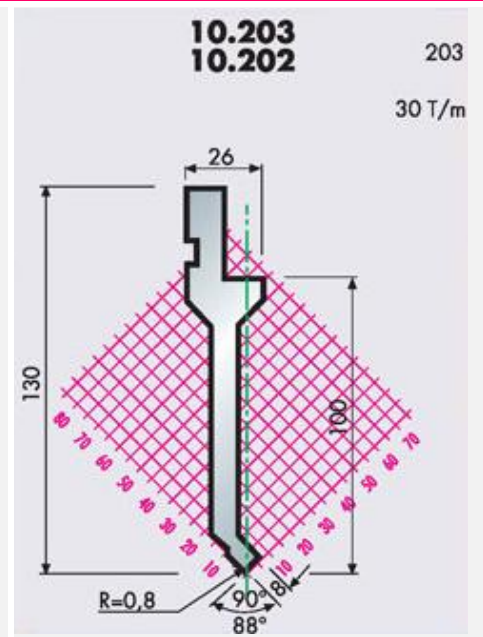
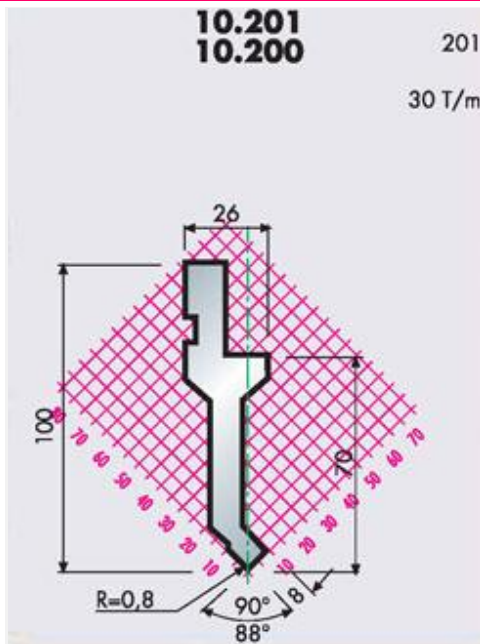
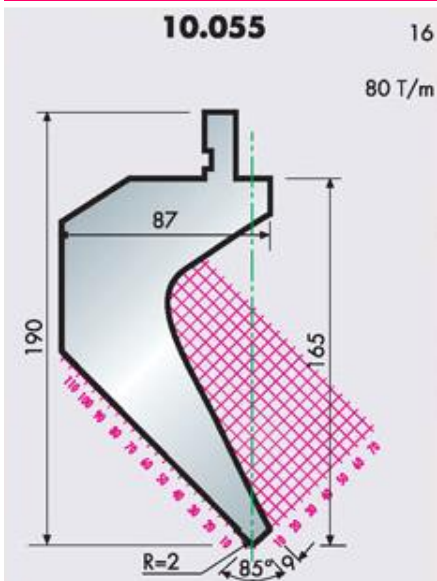

# PUNZONES FERRY PARA PLEGADORA

## TIPO PROMECAM

**10.103**

46

50 T/m

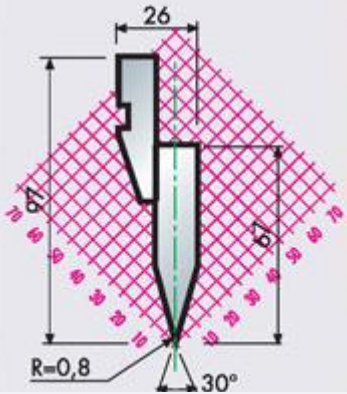

**10.11/45°**

203

70 T/m

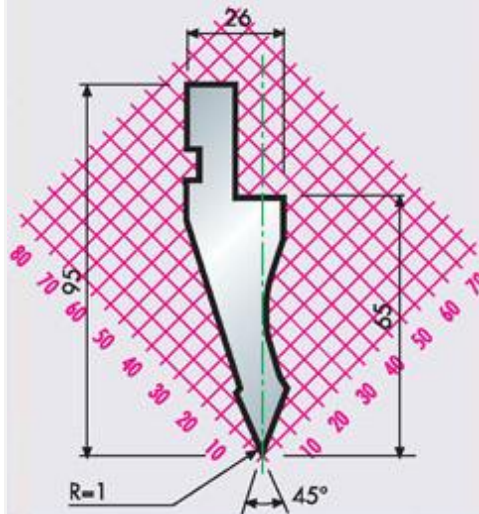

**10.11/35°**

116

50 T/m

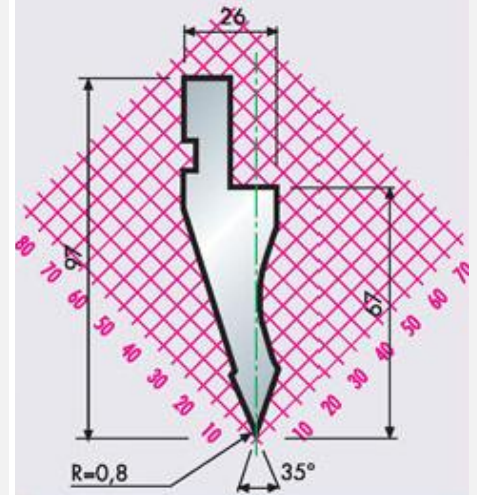

**10.12/35°**

462

70 T/m

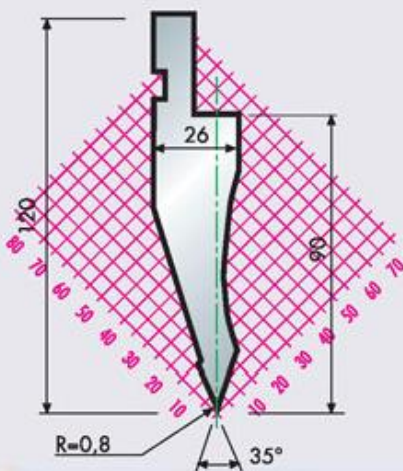

**10.210**

463

50 T/m

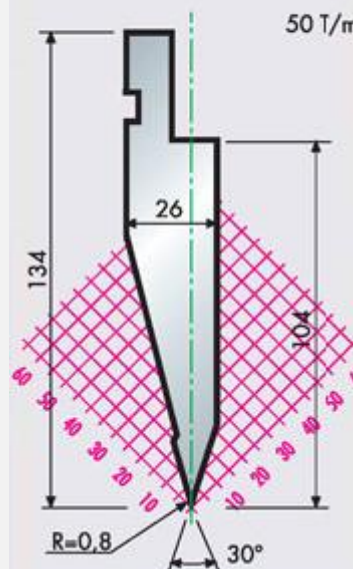

**10.18/26°**

15 T/m

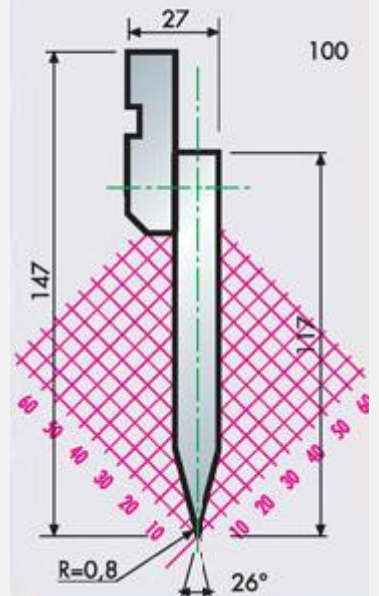

**10.13/60°**

3

100 T/m

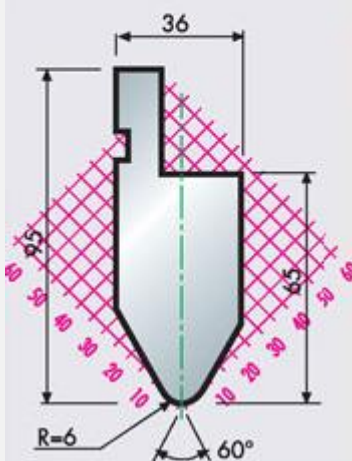

**10.13/35°**

463

100 T/m

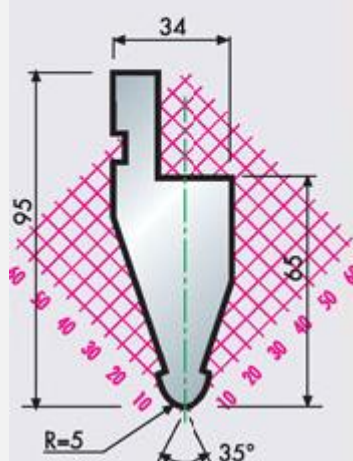

**10.12/35°/R3**

70 T/m

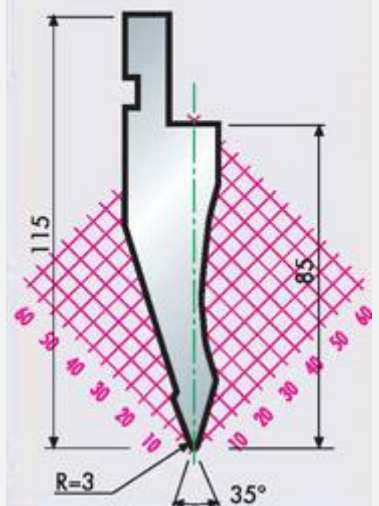

# PUNZONES FERRY PARA PLEGADORA

## TIPO PROMECAM

**10.210/R5**

70 T/m

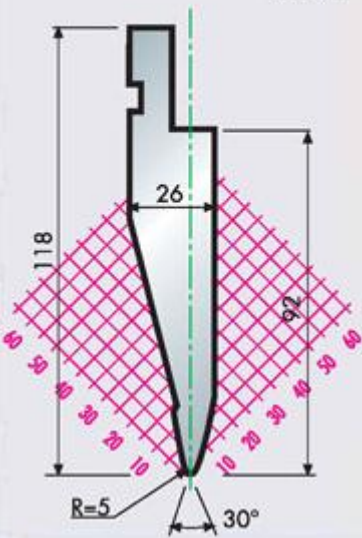

**10.40/60°**

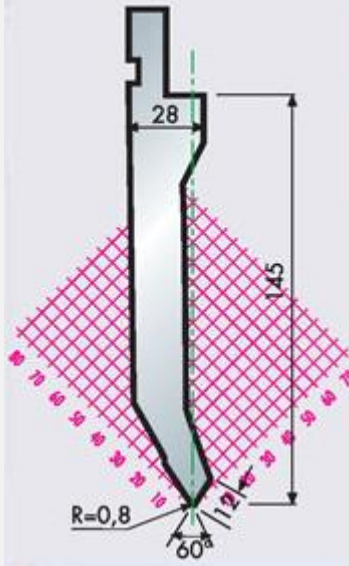

**10.45/26°**

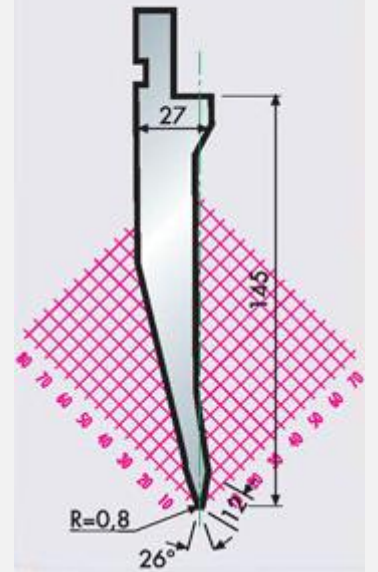

**40.05**

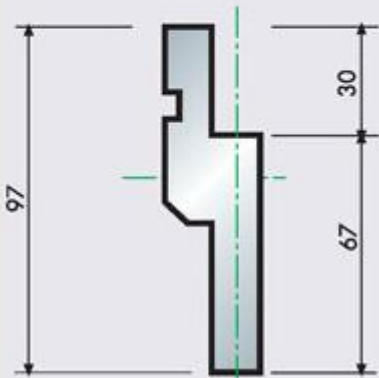

**40.02**

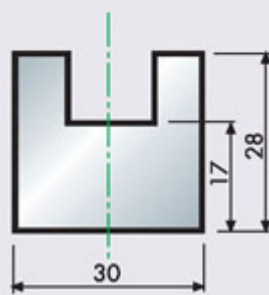

**40,09**

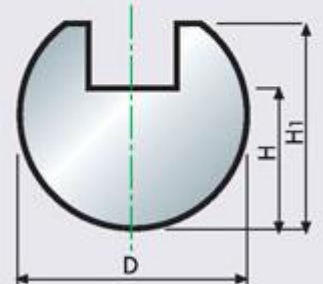

D	20	25	30	35	40	50	60	80	100
H	12	17	20	22	24	29	34	44	70

**40,30**

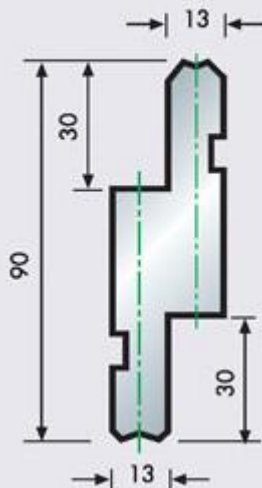

**40.31**

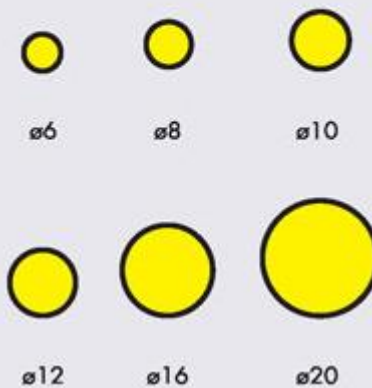

# MATRICES FERRY PARA PLEGADORA

## TIPO PROMECAM

**20.09**

12

100 T/m

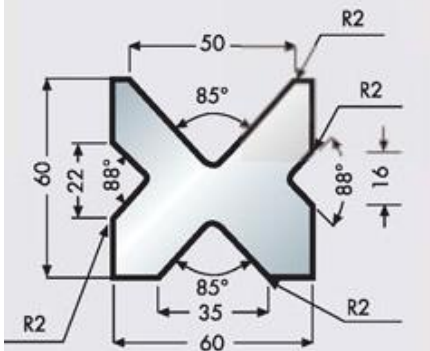

**20.09/60°**

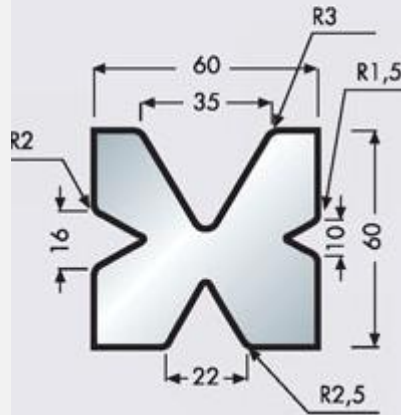

**20.08**

100 T/m

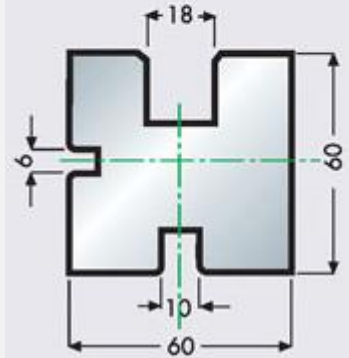

**20.11/32**

35

100 T/m

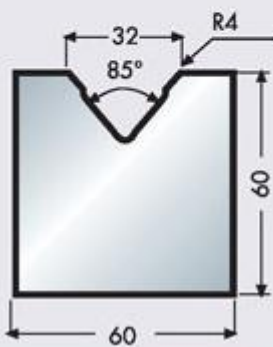

**20.11/40**

36

100 T/m

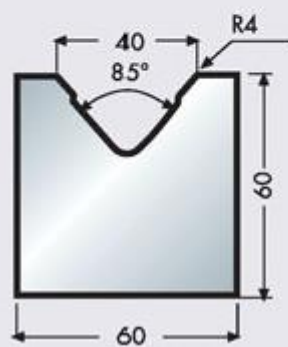

**20.11/50**

37

100 T/m

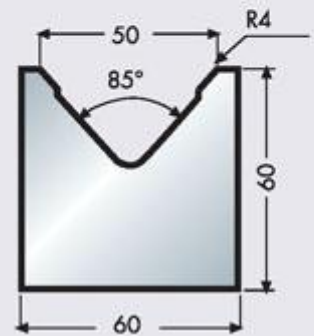

**20.11/63**

38

100 T/m

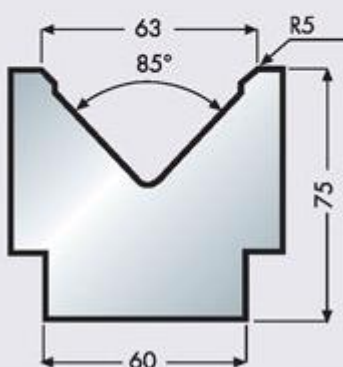

**20.11/80**

13

100 T/m

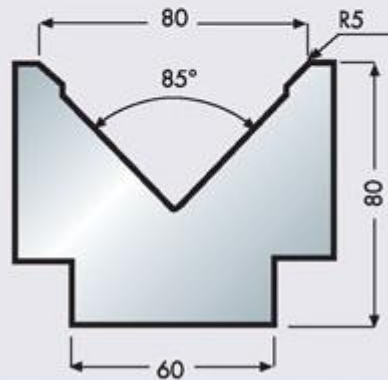

**20.11/100**

18

100 T/m

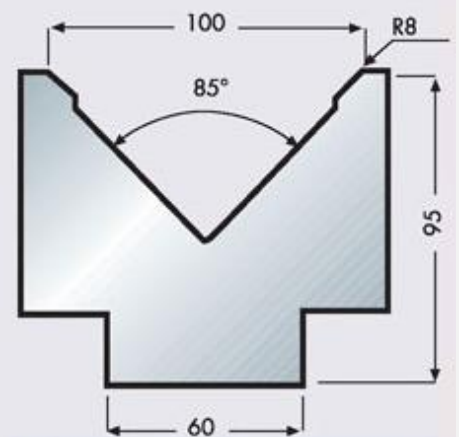

# MATRICES FERRY PARA PLEGADORA

## TIPO PROMECAM

20.11/125

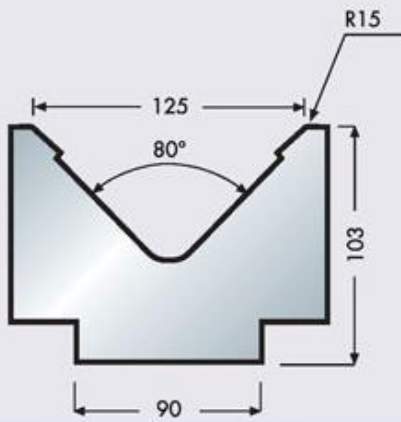

20.11/160

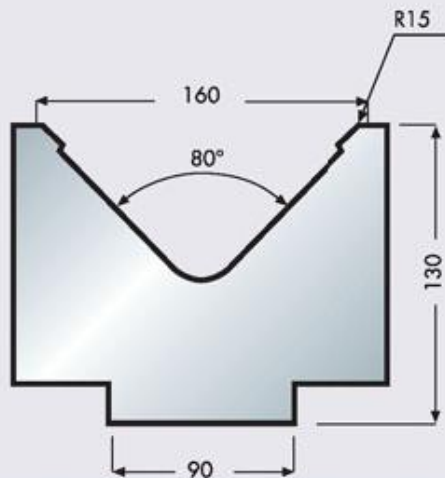

340

203

60 T/m

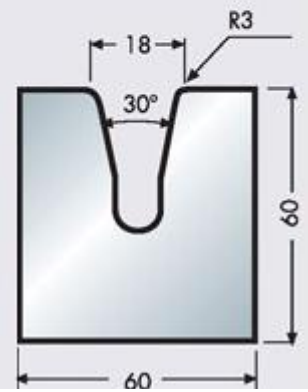

341

462

60 T/m

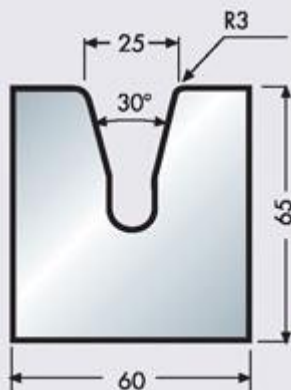

342

463

60 T/m

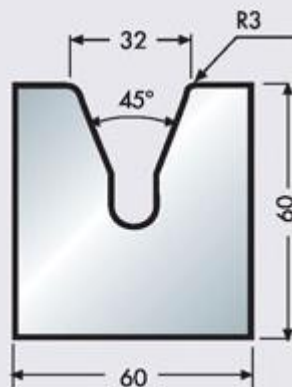

343

46

70 T/m

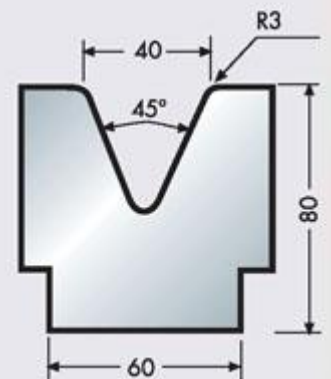

344

70 T/m

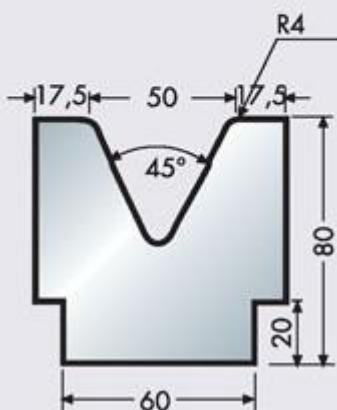

345

70 T/m

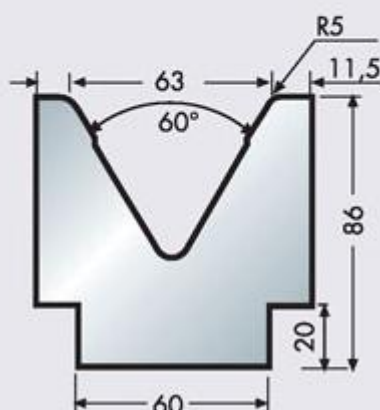

346

90 T/m

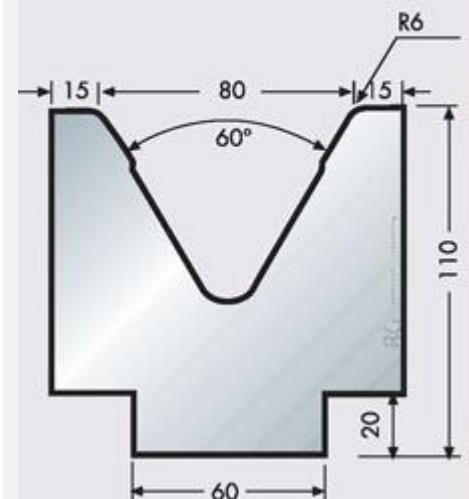

# MATRICES FERRY PARA PLEGADORA

## TIPO PROMECAM

**20.41/90°**

203

95 T/m

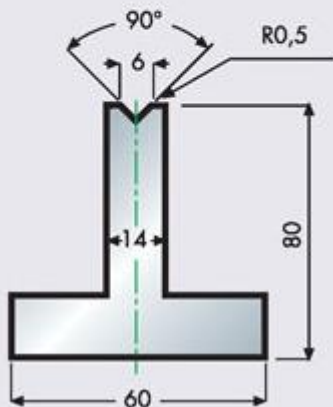

**20.42/88°**  
**20.42/90°**

108

95 T/m

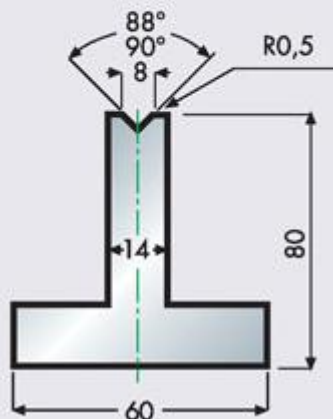

**20.43/88°**  
**20.43/90°**

95 T/m

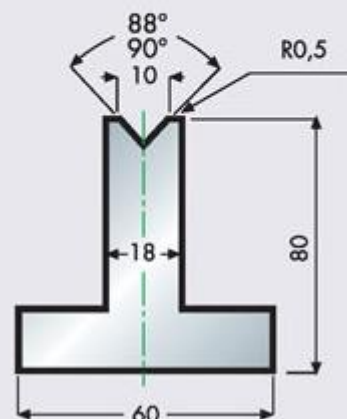

**20.44/88°**  
**20.44/90°**

203

95 T/m

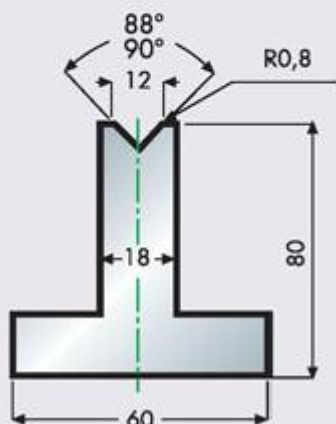

**20.45/88°**

462

95 T/m

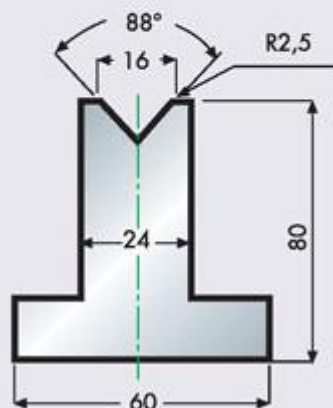

**20.46/88°**

463

95 T/m

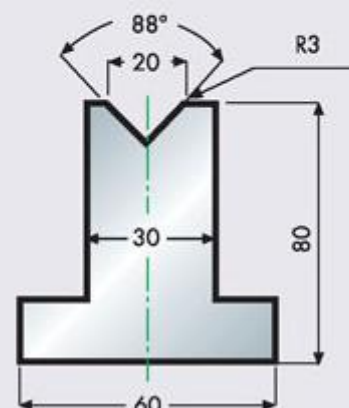

**20.47/85°**

46

100 T/m

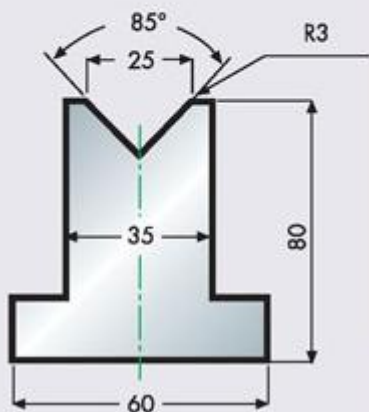

**20.41/60°**

60 T/m

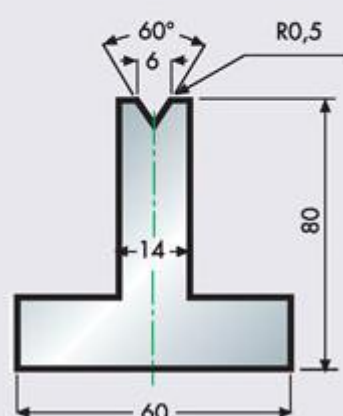

**20.42/60°**

70 T/m

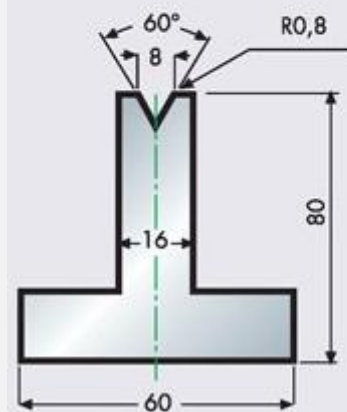

# MATRICES FERRY PARA PLEGADORA

## TIPO PROMECAM

**20.46/35°**

50 T/m

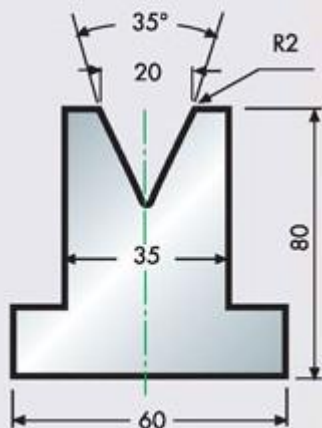

**20.30/35°**

30 T/Mt.

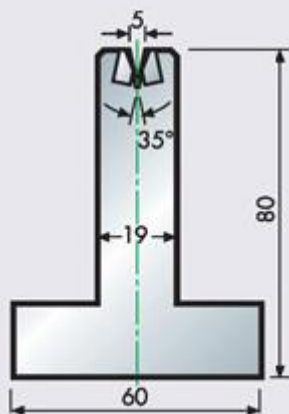

**20.32/35°**

30 T/Mt.

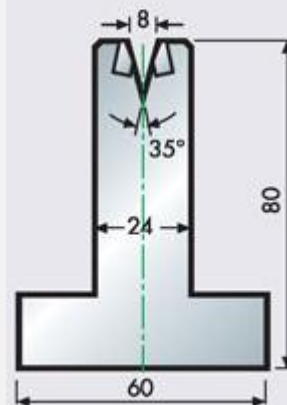

**20.33/35°**

30 T/Mt.

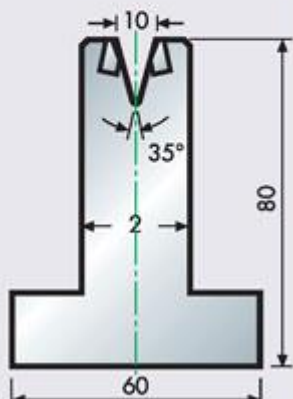

**20.34/35°**

30 T/Mt.

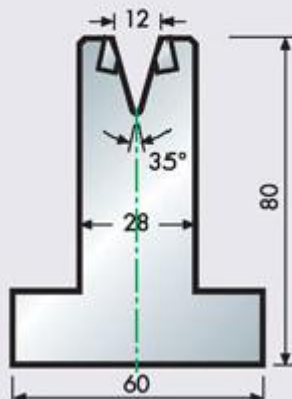

**20.35/35°**

30 T/Mt.

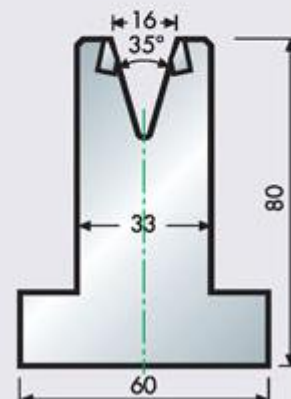

**20.36/35°**

30 T/M

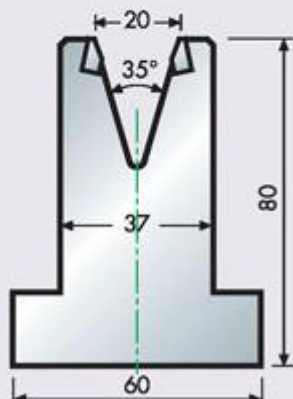

**20.37/35°**

30 T/Mt.

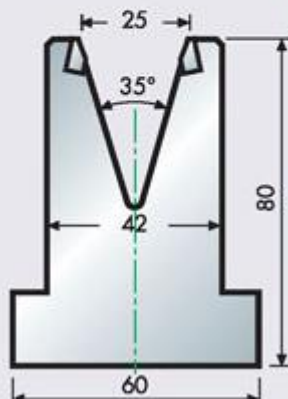

**20.30-T**

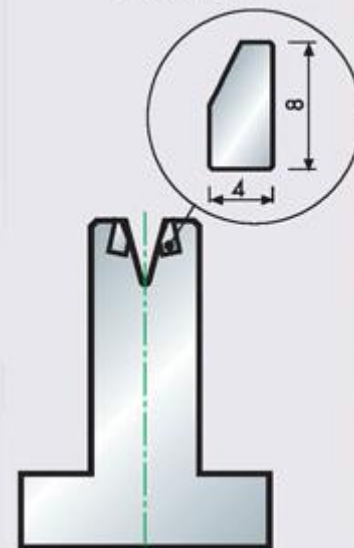



# MATRICES FERRY PARA PLEGADORA

## TIPO PROMECAM

**20.41/90°-120**

95 T/m

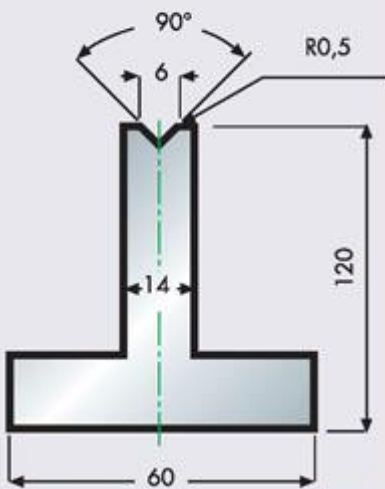

**20.42/88°-120**  
**20.42/90°-120**

95 T/m

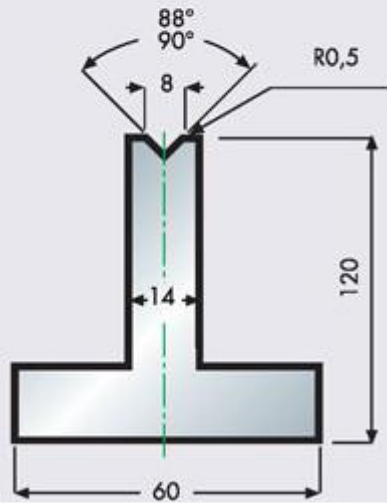

**20.43/88°-120**  
**20.43/90°-120**

95 T/m

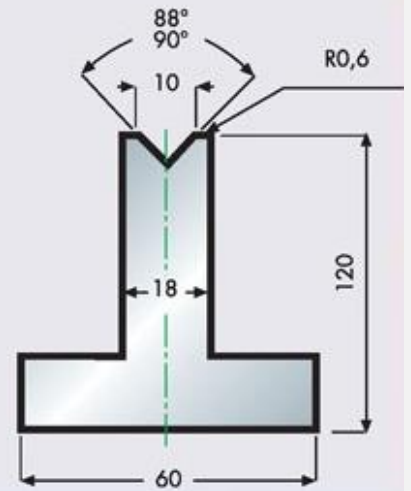

**20.44/88°-120**  
**20.44/90°-120**

95 T/m

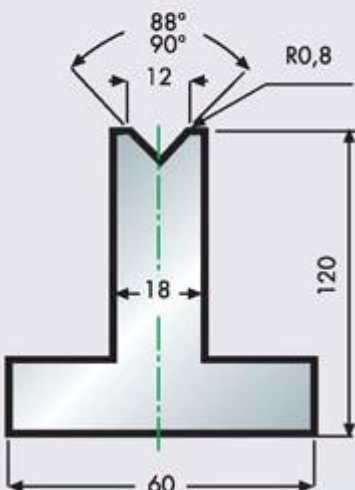

**20.45/88°-120**

95 T/m

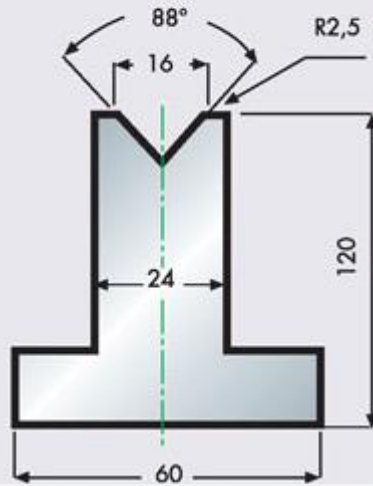

**20.46/88°-120**

95 T/m

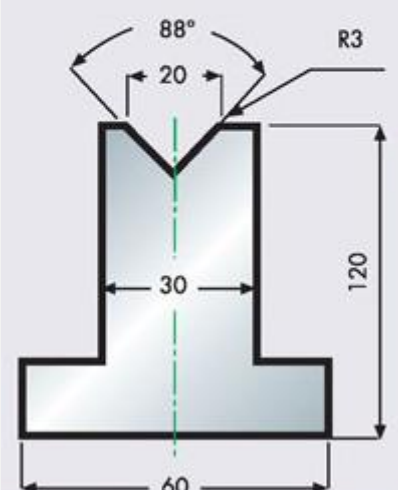

**20.47/85°-120**

100 T/m

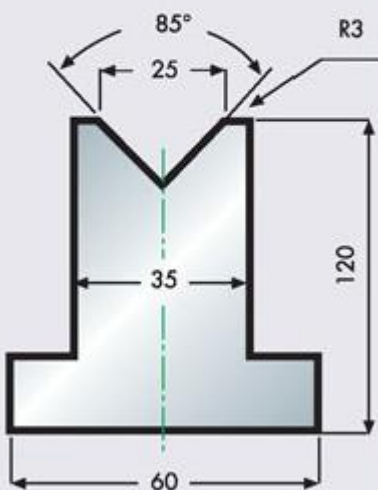

**20.41/60°-120**

60 T/m

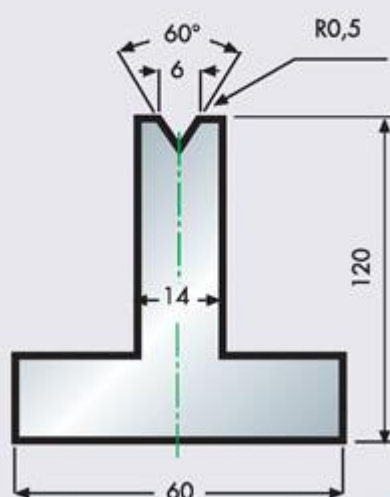

**20.42/60°-120**

70 T/m

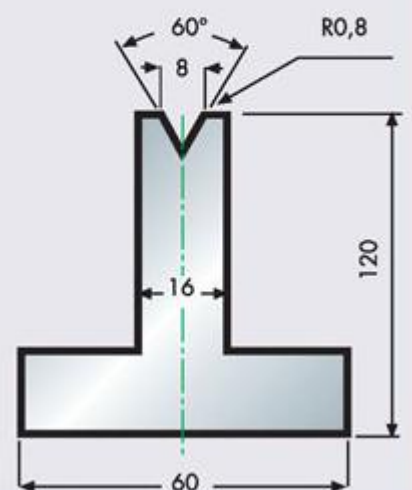

# MATRICES FERRY PARA PLEGADORA

## TIPO PROMECAM

**20.43/60°-120**

70 T/m

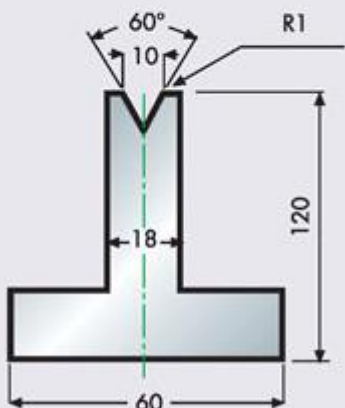

**20.44/60°-120**

70 T/m

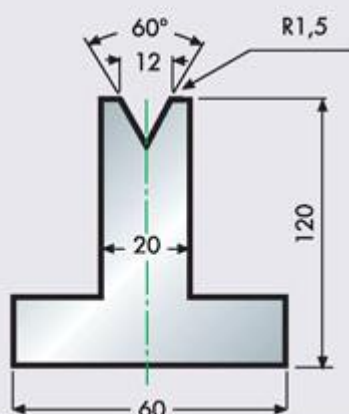

**20.45/60°-120**

70 T/m

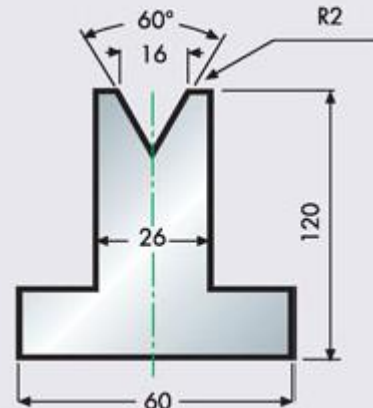

**20.46/60°-120**

70 T/m

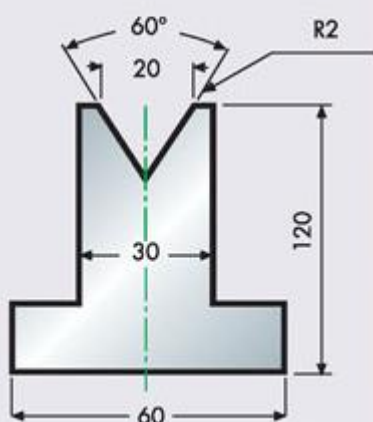

**20.41/35°-120**

50 T/m

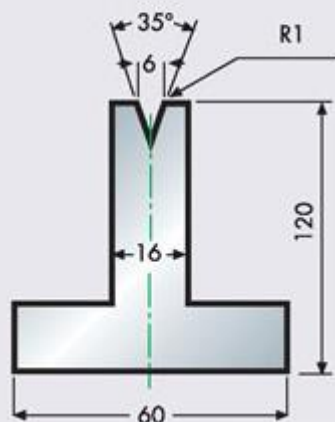

**20.42/35°-120**

50 T/m

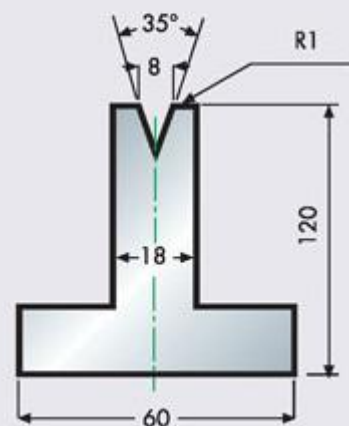

**20.43/35°-120**

50 T/m

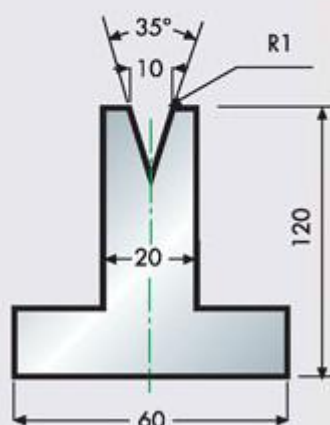

**20.44/35°-120**

50 T/m

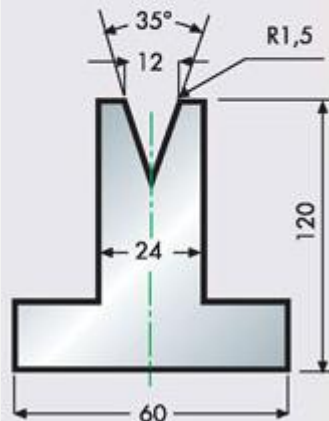

**20.45/35°-120**

50 T/m

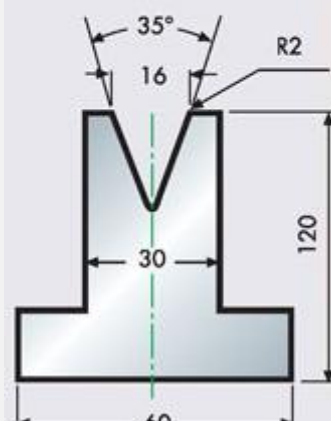

# MATRICES FERRY PARA PLEGADORA

## TIPO PROMECAM

**20.46/35°-120**

50 T/m

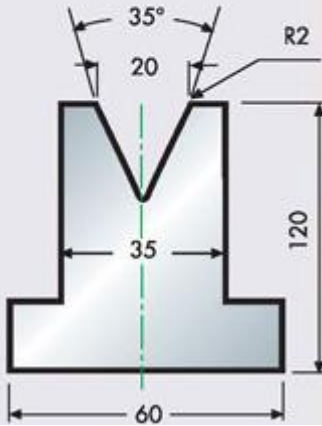

**20.12/88°** 311  
**20.12/90°**

80 T/m

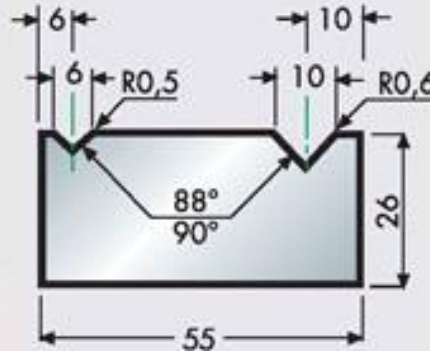

**20.13/88°** 312  
**20.13/90°**

80 T/m

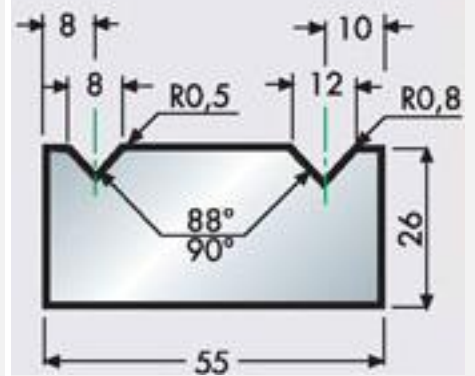

**20.14/88°** 314

100 T/m

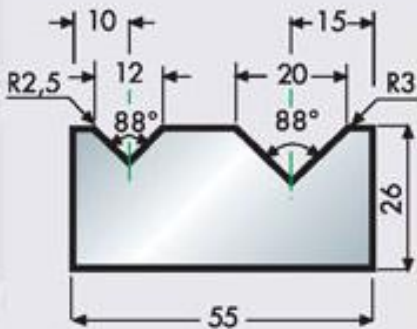

**20.15/88°** 315

100 T/m

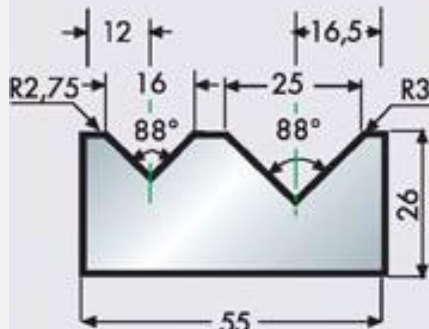

**121/88°**  
**121/90°**

60 T/m

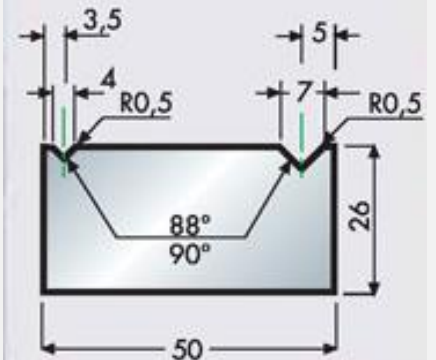

**123/88°**  
**123/90°**

70 T/m

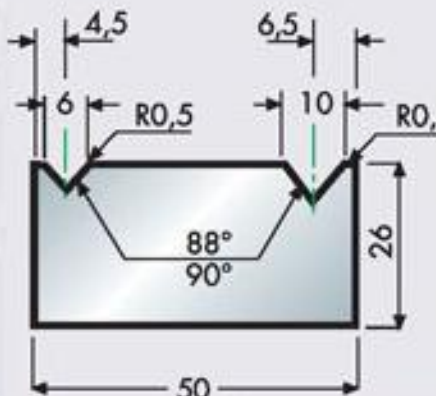

**124/88°**  
**124/90°**

80 T/m

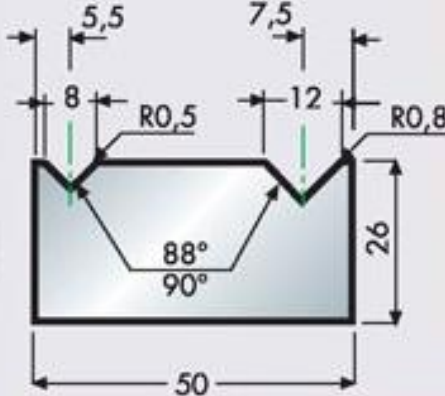

**125/88°**

100 T/m

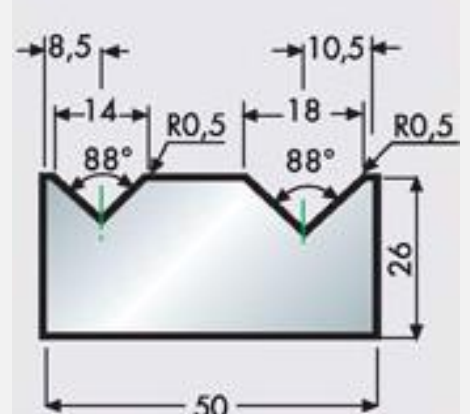

# MATRICES FERRY PARA PLEGADORA

## TIPO PROMECAM

**126/88°**

100 T/m

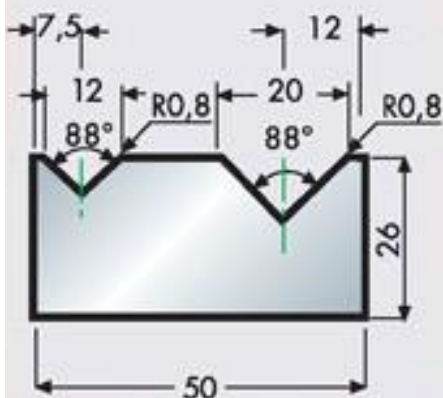

**127/88°**

70 T/m

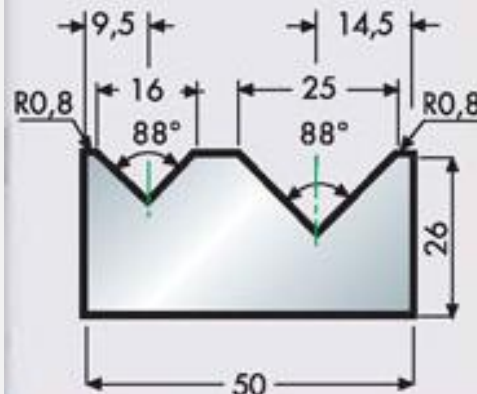

**20.12/35°**

70 T/m

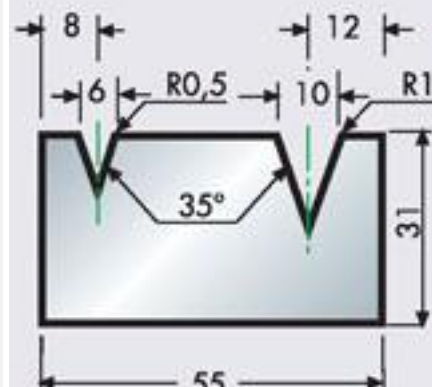

**20.13/35°**

70 T/m

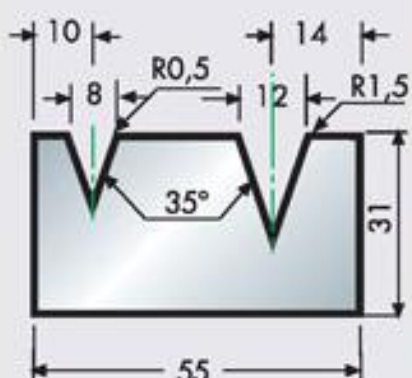

**20.14/60°**

70 T/m

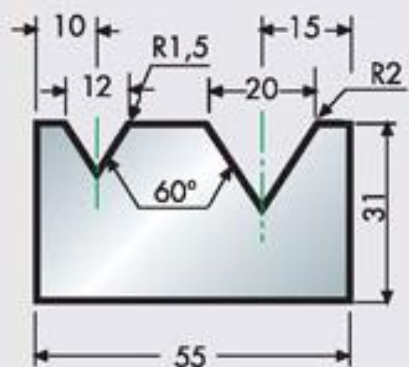

**20.15/60°**

70 T/m

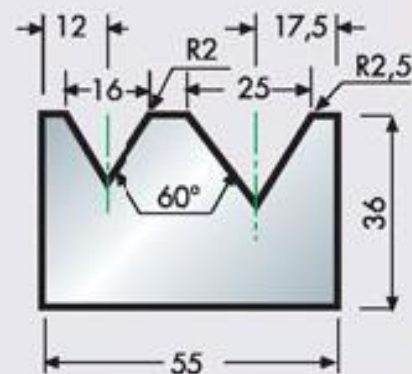

**20.12/35°**

70 T/m

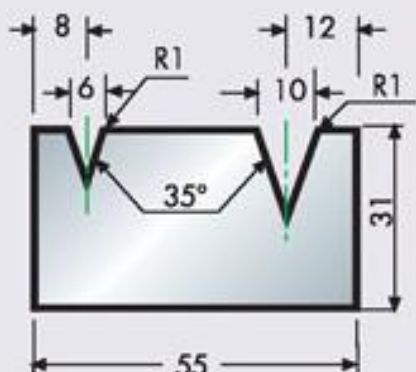

**20.13/35°**

70 T/m

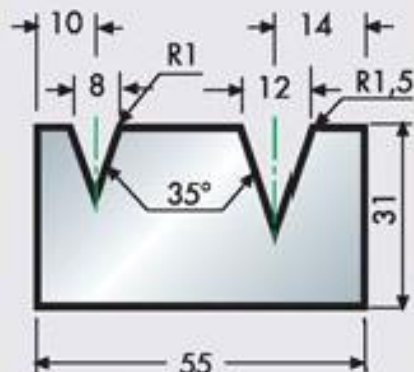

**501/88°**  
**501/90°**

60 T/m

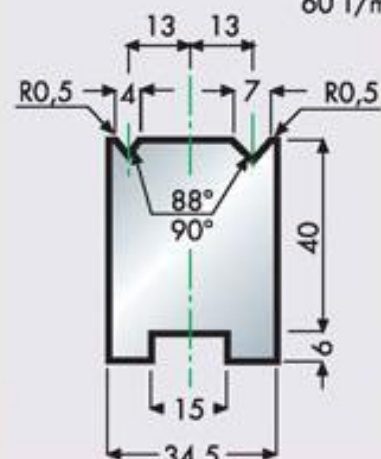

# MATRICES FERRY PARA PLEGADORA

## TIPO PROMECAM

**502/88°**  
**502/90°**

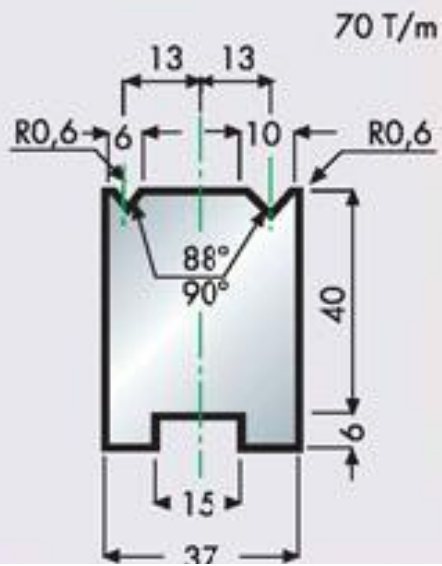

**503/88°**  
**503/90°**

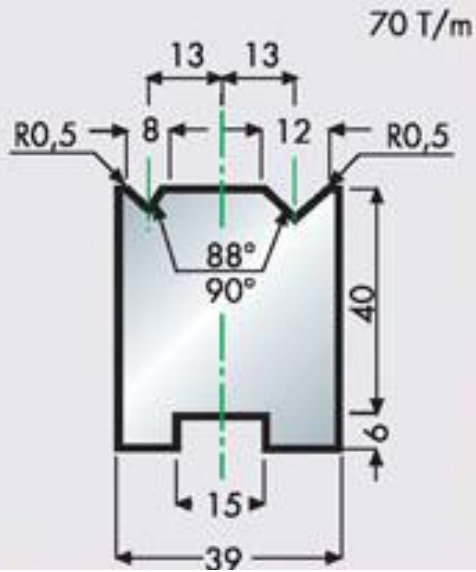

**504/88°**

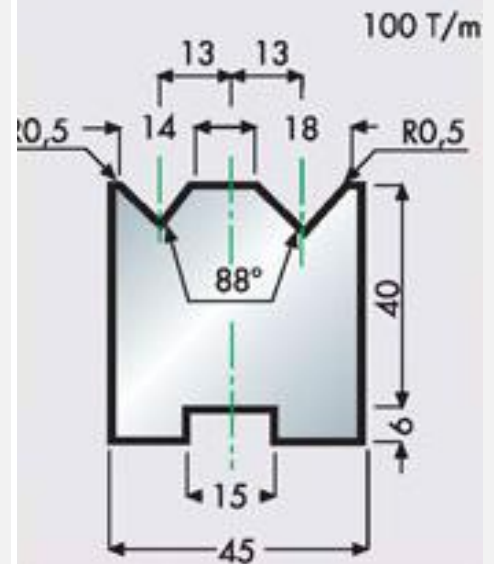

**505/88°**

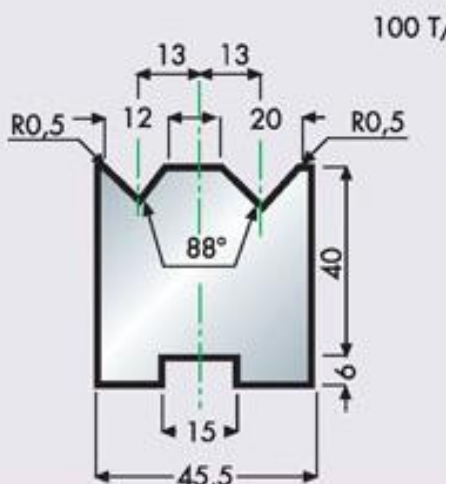

**506/88°**

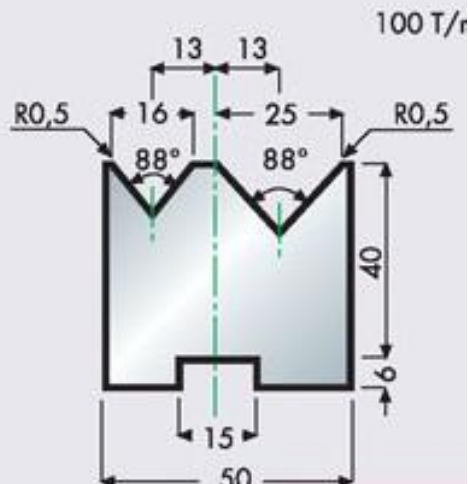

**40.15**

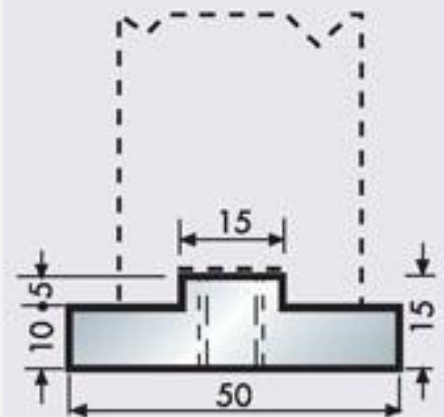

**40.06/34**

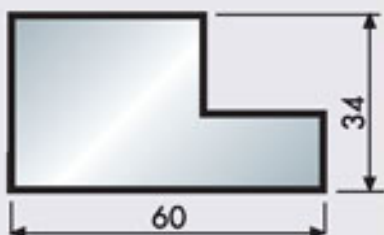

**40.06/39**

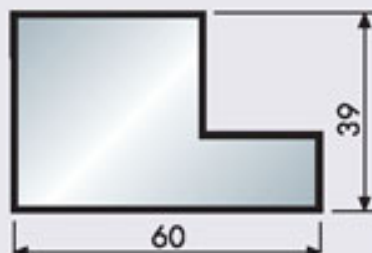

**40.07/55**

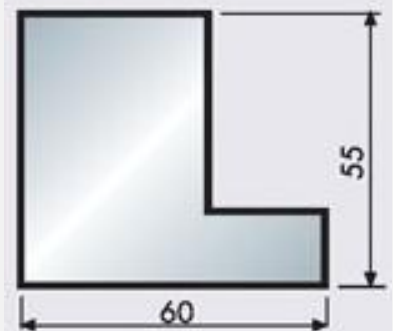

# MATRICES FERRY PARA PLEGADORA

## TIPO PROMECAM

**40.07/75**

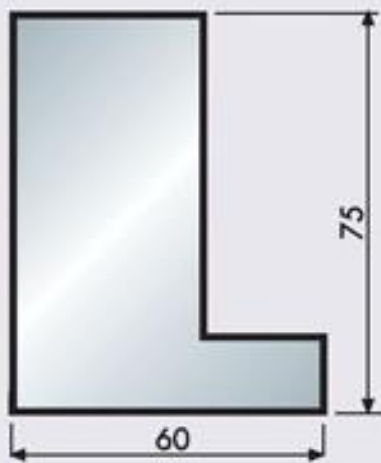

**70.88**

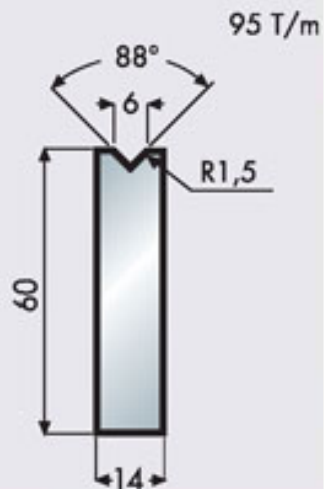

**71.88**

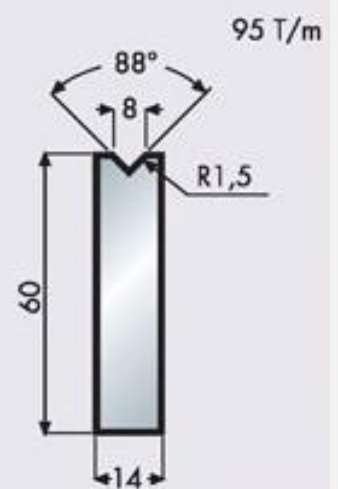

**72.88**

108

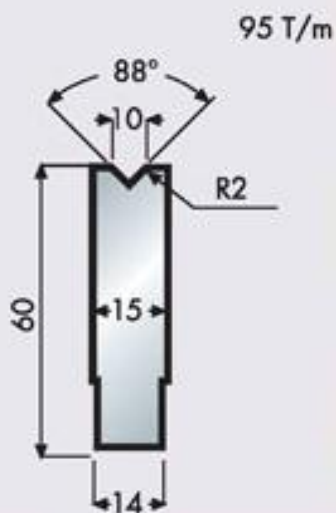

**74.88**

95 T/m

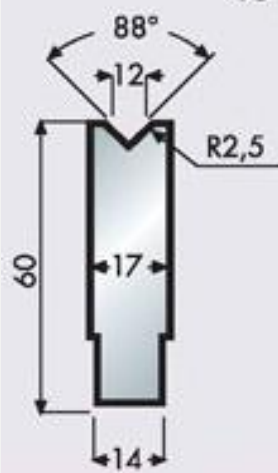

**76.88**

95 T/m

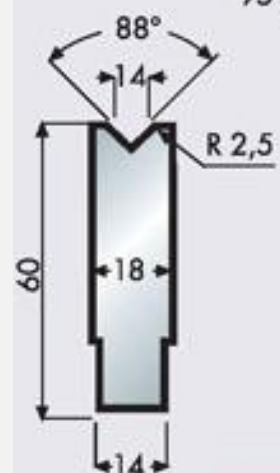

**77.88**

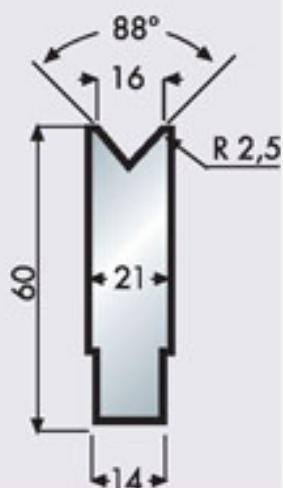

**78.88**

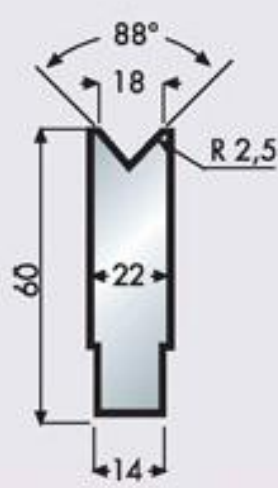

**79.88**

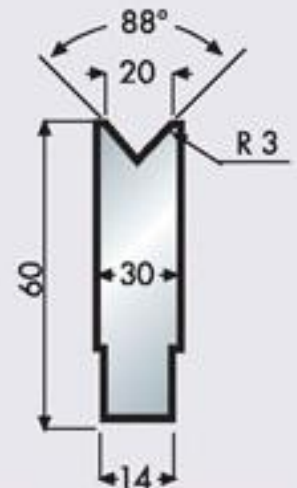

# MATRICES FERRY PARA PLEGADORA

## TIPO PROMECAM

**80.88**

95 T/m

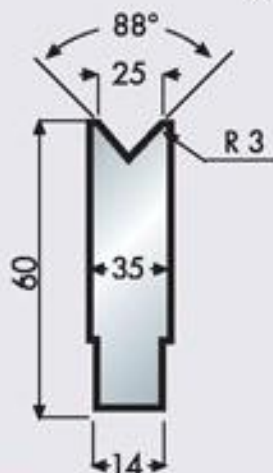

**70.60°**

60 T/m

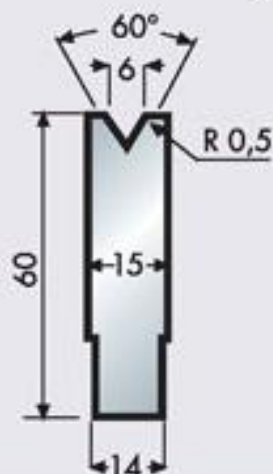

**71.60°**

70 T/m

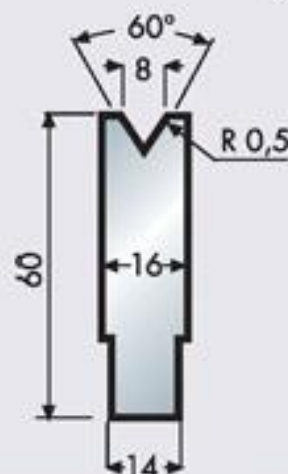

**73.60°**

70 T/m

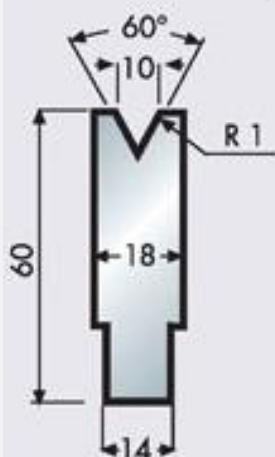

**75.60°**

70

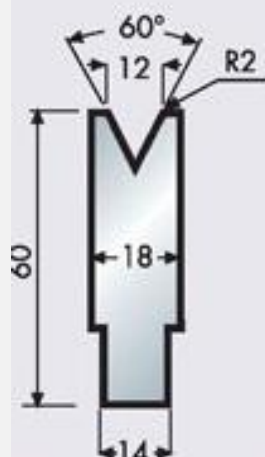

**77.60°**

70 T/m

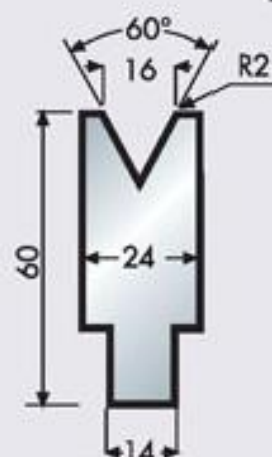

**78.60°**

70 T/m

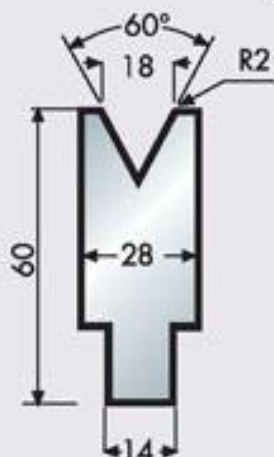

**79.60°**

70 T/m

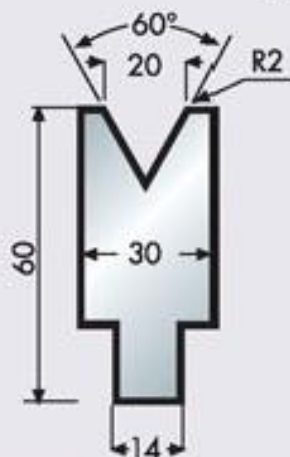

**80.60°**

70 T/m

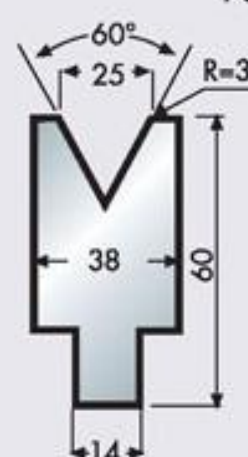

# MATRICES FERRY PARA PLEGADORA

## TIPO PROMECAM

**70.35°**

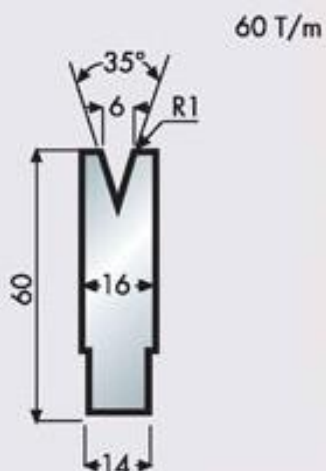

**71.35°**

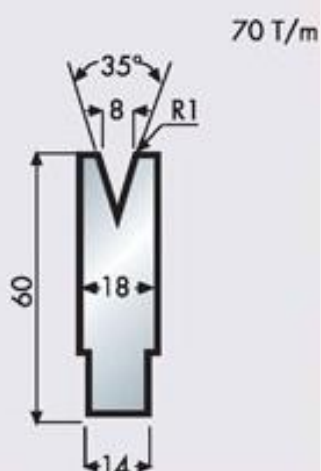

**73.35°**

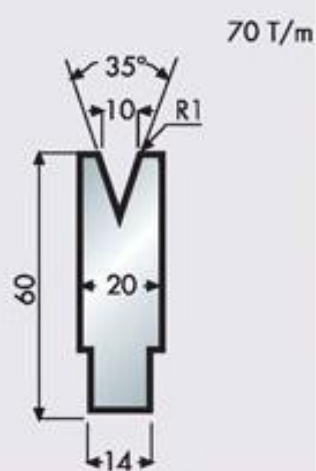

**75.35°**

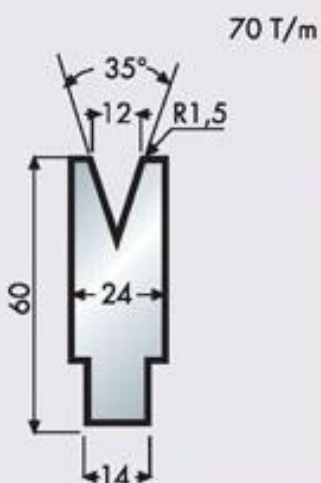

**77.35°**

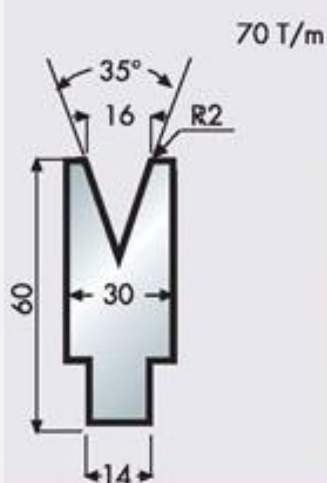

**79.35°**

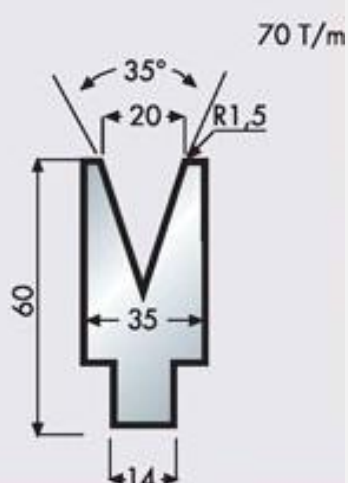

**40.14**

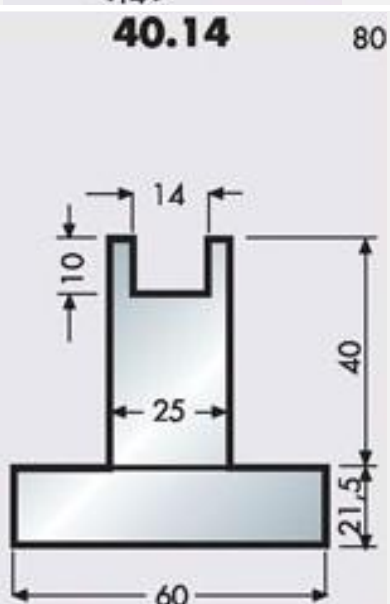

**320/88°**

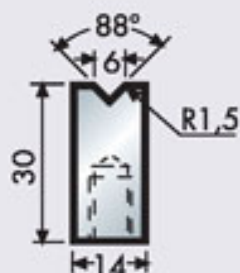

**321/88°**

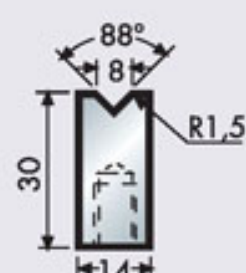



# MATRICES FERRY PARA PLEGADORA

## TIPO PROMECAM

**322/88°**

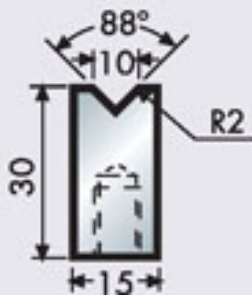

**326/88°**

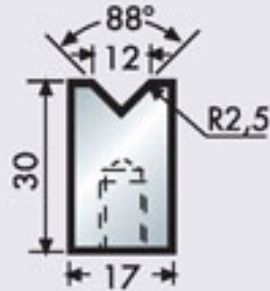

**325/88°**

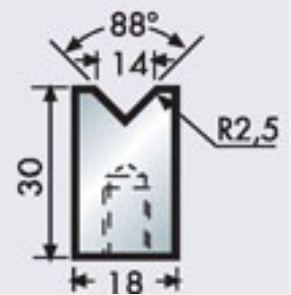

**330**

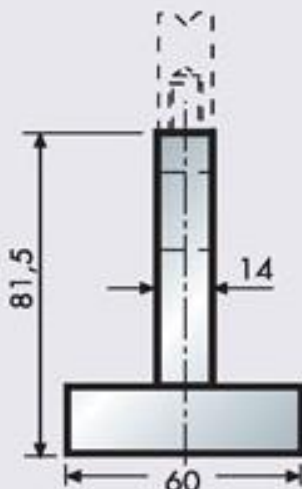

**20.16/90°**

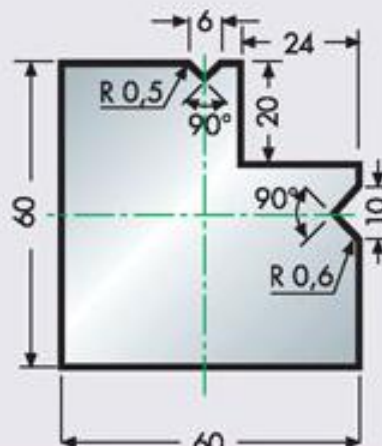

**20.17/90°**

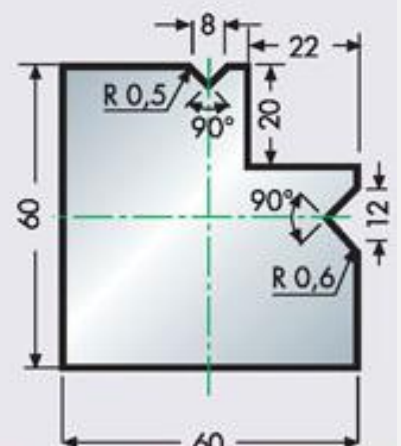

**61.1**

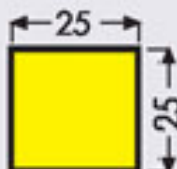

**61.3**

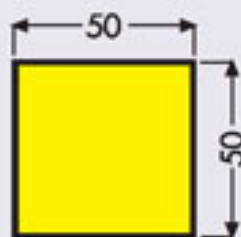

**61.4**

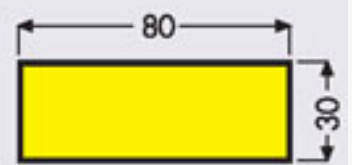

# MATRICES FERRY PARA PLEGADORA

## TIPO PROMECAM

**61.5**

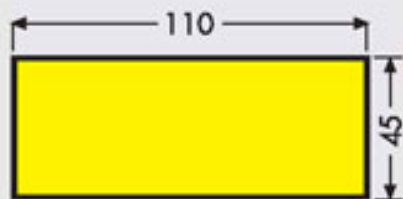

**60.1**

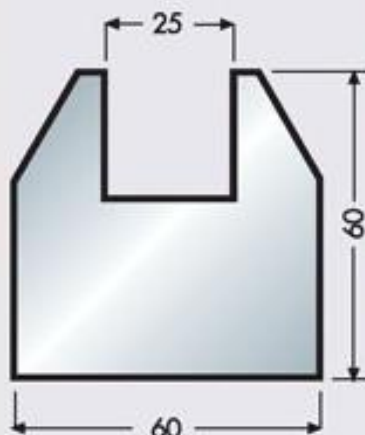

**60.3**

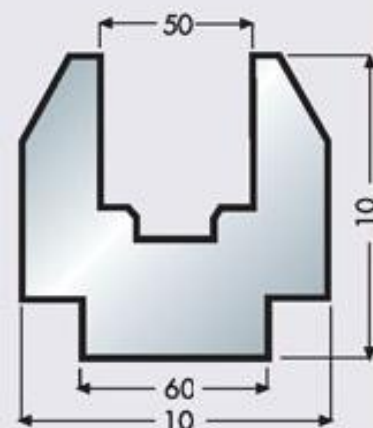

**60.4**

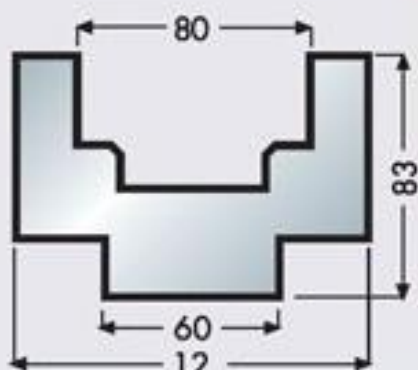

**60.5**

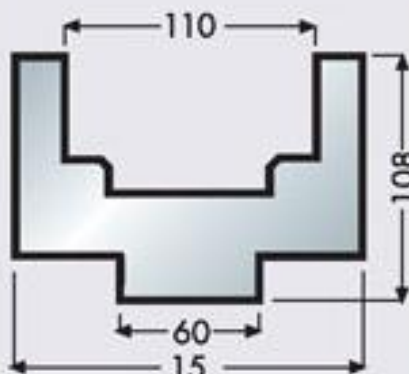

**30.01/6-35°**

60 T/m

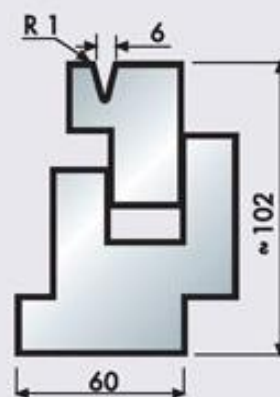

**30.01/8-35°**

50 T/m

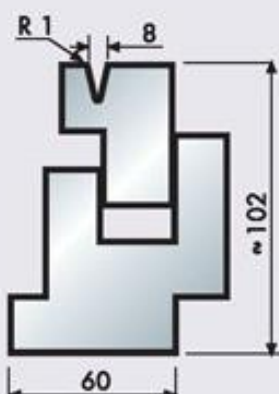

**30.02/6-35°**

60 T/m

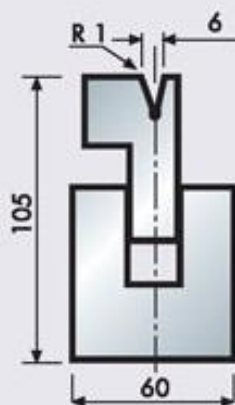

**30.02/8-30°**

50 T/m

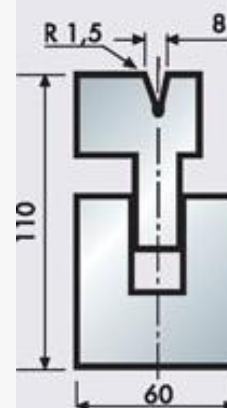

# MATRICES FERRY PARA PLEGADORA

## TIPO PROMECAM

**30.01/10-35°**

65 T/m

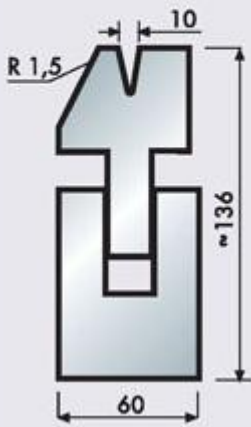

**30.01/12-35°**

65 T/m

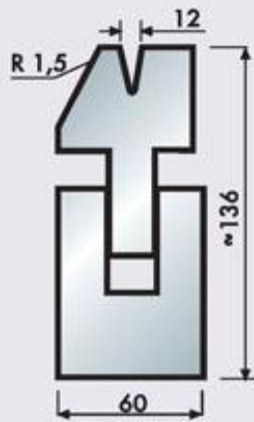

**30.01/12-26°**

65 T/m

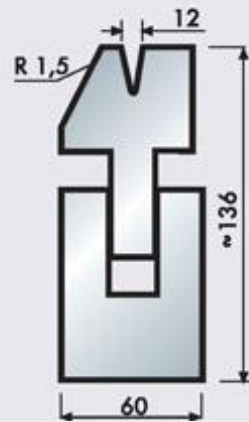

**30.01/10-26°**

65 T/m

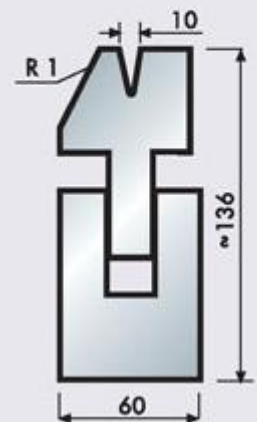

**30.01- P8**

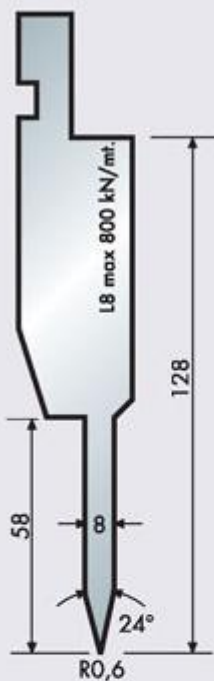

**30.01- P10**

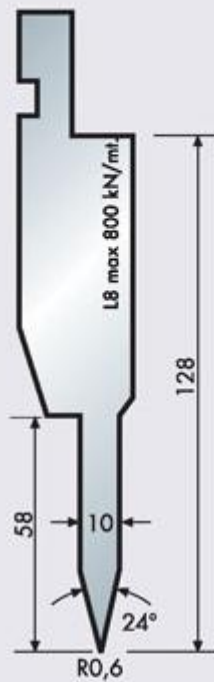

**30.01- P12**

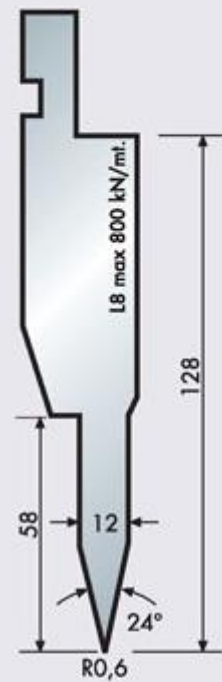

**30.01- M8**

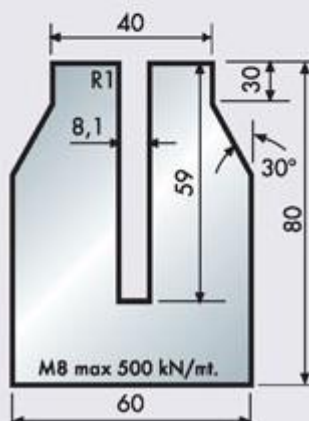

**30.01- M10**

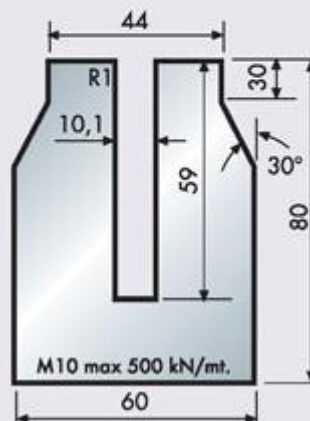

**30.01- M12**

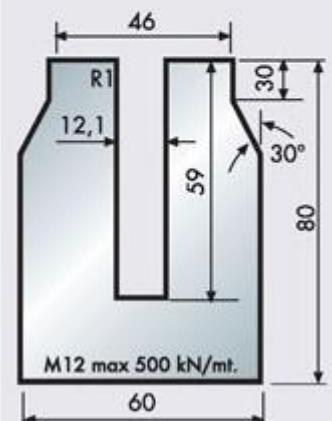

# BRIDAS E INTERMEDIARIOS

## TIPO PROMECAM

**40.03**

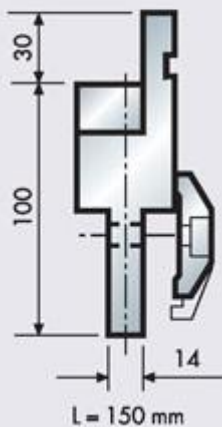

**40.50**

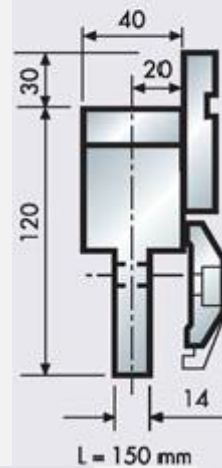

**ST41**

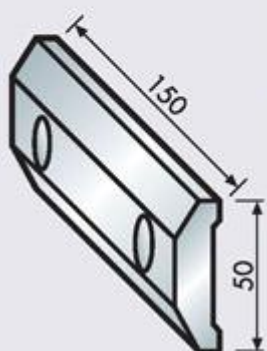

**ST42**

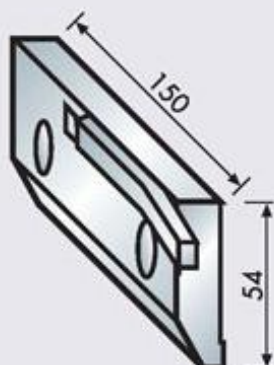

**ST43**

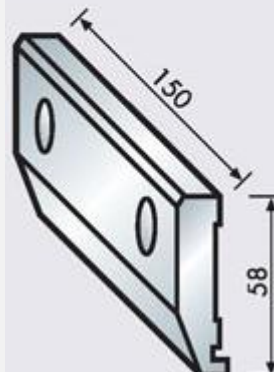

**ST44**

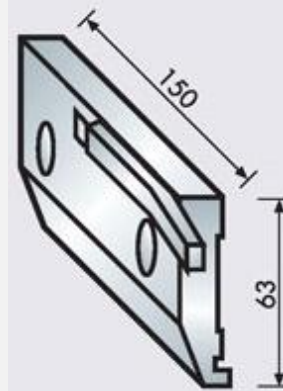

**40.55**

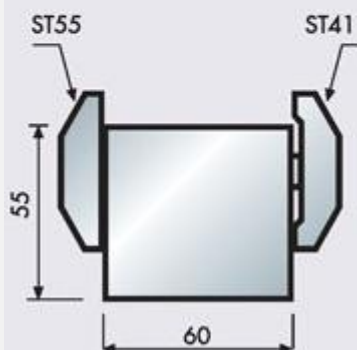

**8053**

